



Diesel Sound Attenuated Single phase BG22

	Prime	Standby
Genset model	EA5-BG22P	EA5-BG22S
220-240V, 50Hz	15.1kVA	16.6kVA
	15.1kW	16.6kW
220/110V, 60Hz	18.0kVA	20.0kVA
	18.0kW	20.0kW

Ratings at 1.0 pf

Prime:

This rating is for the supply of continuous electrical power (at variable load) in lieu of commercially purchased power. There is no limitation on the annual hours of operation and 10% overload power can be supplied for one hour in twelve hours.

Standby:

This rating is for the supply of continuous electrical power (at variable load) in the event of a utility power failure. No overload is permitted.



Engine model	Perkins	404D-22G
Number of cylinders	4 in-line	
Cubic capacity	litre (cu inch)	2.22 (135)
Aspiration	Naturally Aspirated	
Alternator	European	



Genset photograph may include optional extras

Frequency		50Hz	60Hz
Engine speed	rpm	1,500	1,800
Fuel tank capacity	litre (USgal)	100 (26.4)	100 (26.4)
Fuel consumption at full rating: Prime	litre /h (USgal /h)	5.40 (1.43)	6.20 (1.64)
Standby	litre /h (USgal /h)	6.20 (1.64)	6.90 (1.82)
Heat rejection to exhaust system (max)	kW (BTU /min)	16.6 (945)	18.3 (1,042)
Heat rejection to cooling system (max)	kW (BTU /min)	19.6 (1,116)	22.2 (1,264)
Total radiated heat (max)	kW (BTU /min)	NA	NA
Exhaust temperature (max)	deg C (deg F)	505 (941)	510 (950)
Radiator cooling air flow	cu m /min (cfm)	NA	NA
with max restriction	mm (inch) H ₂ O	NA	NA
Combustion air flow (max)	cu m /min (cfm)	1.45 (51.0)	1.74 (61.0)
Exhaust gas flow (max)	cu m /min (cfm)	NA	NA
with max allowable back pressure	mm (inch) H ₂ O	NA	NA

Note: Standard reference conditions: 25°C (77°F) air inlet temperature, 152.4m (500ft) above sea level, 60% relative humidity. All engine performance data based on the above mentioned maximum continuous ratings. Fuel consumption data at full load for diesel fuel with specific gravity of 0.85 and conforming to BS2869: 1998, class A2.



BurtonwoodTM

Generator & Switchgear Services

Data Sheet EA5-BG22

Dimensions:		
Length (A)	mm (inch)	1,946 (76.6)
Width (B)	mm (inch)	720 (28.3)
Height (C)	mm (inch)	1,369 (53.9)
Max longitudinal projection (D)	mm (inch)	Not applicable
Max width projection per side (E)	mm (inch)	816 (32.1)
Maximum height total (F)	mm (inch)	1,775 (69.9)

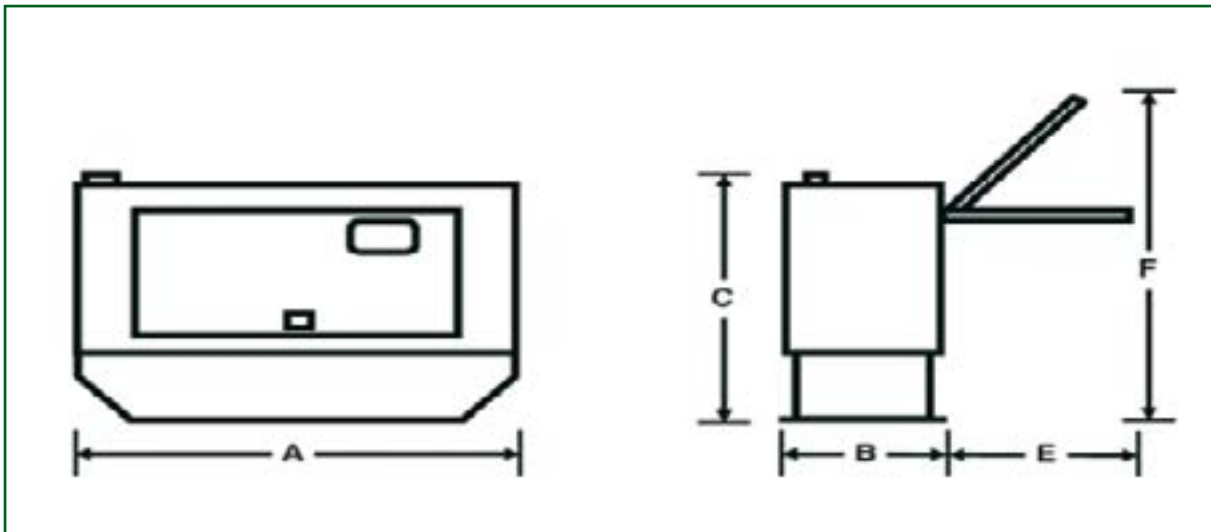

Weights:		
Dry weight (with lube oil)	kg (lb)	572 (1,261)
Wet weight (with lube oil and coolant)	kg (lb)	580 (1,279)

Sound pressure levels:		50Hz	60Hz
		1500rpm	1800rpm
15m, 75% load	dB(A)	58.3	TBA
15m, 100% load	dB(A)	60.1	TBA
7m, 75% load	dB(A)	64.3	TBA
7m, 100% load	dB(A)	66.1	TBA
1m, 75% load	dB(A)	73.8	TBA
1m, 100% load	dB(A)	74.6	TBA

In line with our policy of continuous development, we reserve the right to change specification without notice

EA5-BG22 - DS-332-0311