



Diesel Sound Attenuated Three phase BG10

	Prime	Standby
Genset model	EA3-BG10P	EA3-BG10S
380-415V, 50Hz	9.0kVA	10.0kVA
	7.2kW	8.0kW
220/127V, 60Hz	11.3kVA	12.5kVA
	9.0kW	10.0kW

Ratings at 0.8 pf

Prime:
This rating is for the supply of continuous electrical power (at variable load) in lieu of commercially purchased power.
There is no limitation on the annual hours of operation and 10% overload power can be supplied for one hour in twelve hours.

Standby:
This rating is for the supply of continuous electrical power (at variable load) in the event of a utility power failure.
No overload is permitted.



Engine model	Perkins	403D-11G
Number of cylinders	3 in-line	
Cubic capacity	litre (cu inch)	1.13 (69.0)
Aspiration	Naturally Aspirated	
Alternator	European	



Genset photograph may include optional extras

Frequency		50Hz	60Hz
Engine speed	rpm	1,500	1,800
Fuel tank capacity	litre (USgal)	100 (26.4)	100 (26.4)
Fuel consumption at full rating: Prime	litre /h (USgal /h)	2.60 (0.69)	3.00 (0.79)
Standby	litre /h (USgal /h)	2.90 (0.77)	3.60 (0.95)
Heat rejection to exhaust system (max)	kW (BTU /min)	8.0 (455)	10.8 (615)
Heat rejection to cooling system (max)	kW (BTU /min)	9.5 (541)	12.1 (689)
Total radiated heat (max)	kW (BTU /min)	Not applicable	Not applicable
Exhaust temperature (max)	deg C (deg F)	420 (788)	515 (959)
Radiator cooling air flow	cu m /min (cfm)	Not applicable	Not applicable
with max restriction	mm (inch) H ₂ O	Not applicable	Not applicable
Combustion air flow (max)	cu m /min (cfm)	0.70 (25)	0.90 (32)
Exhaust gas flow (max)	cu m /min (cfm)	Not applicable	Not applicable
with max allowable back pressure	mm (inch) H ₂ O	Not applicable	Not applicable

Note: Standard reference conditions: 25°C (77°F) air inlet temperature, 152.4m (500ft) above sea level, 60% relative humidity. All engine performance data based on the above mentioned maximum continuous ratings. Fuel consumption data at full load for diesel fuel with specific gravity of 0.85 and conforming to BS2869: 1998, class A2.



Burtonwood™

Generator & Switchgear Services

Data Sheet EA3-BG10



Diesel Sound Attenuated Three phase BG10

Dimensions:		
Length (A)	mm (inch)	1,946 (76.6)
Width (B)	mm (inch)	720 (28.3)
Height (C)	mm (inch)	1,369 (56.9)
Max longitudinal projection (D)	mm (inch)	Not applicable
Max width projection per side (E)	mm (inch)	813 (32.0)
Max height total (F)	mm (inch)	1,775 (69.9)

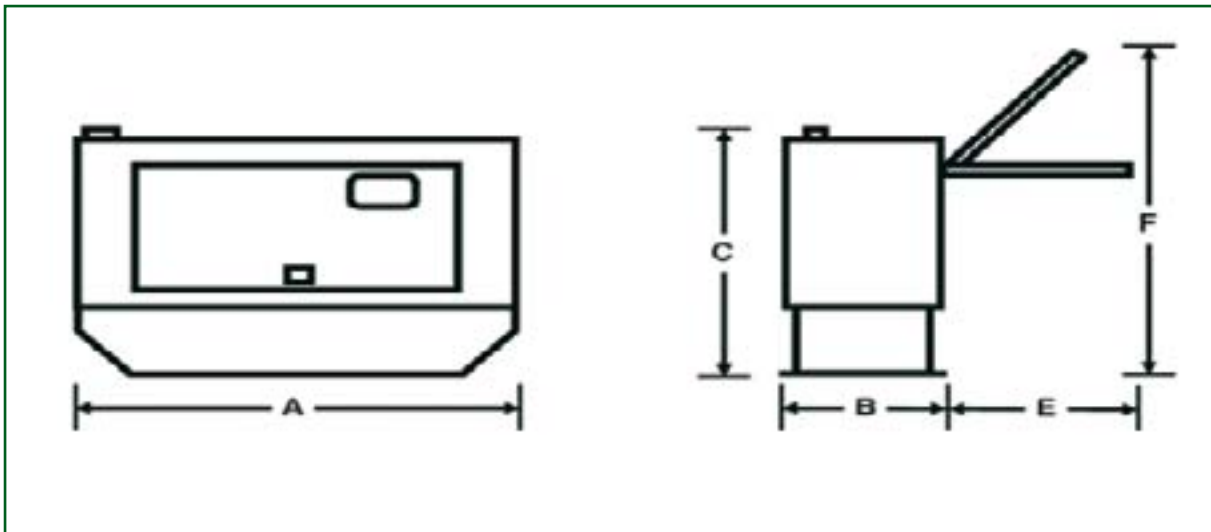

Weights:		
Dry weight (with lube oil)	kg (lb)	452 (996)
Wet weight (with lube oil and coolant)	kg (lb)	460 (1,014)

Sound pressure levels:		50Hz	60Hz
		1500rpm	1800rpm
15m, 75% load	dB(A)	65.4	TBA
15m, 100% load	dB(A)	TBA	TBA
7m, 75% load	dB(A)	72.0	TBA
7m, 100% load	dB(A)	TBA	TBA
1m, 75% load	dB(A)	80.6	TBA
1m, 100% load	dB(A)	TBA	TBA

In line with our policy of continuous development, we reserve the right to change specification without notice

EA3-BG10 - DS-327-0311